

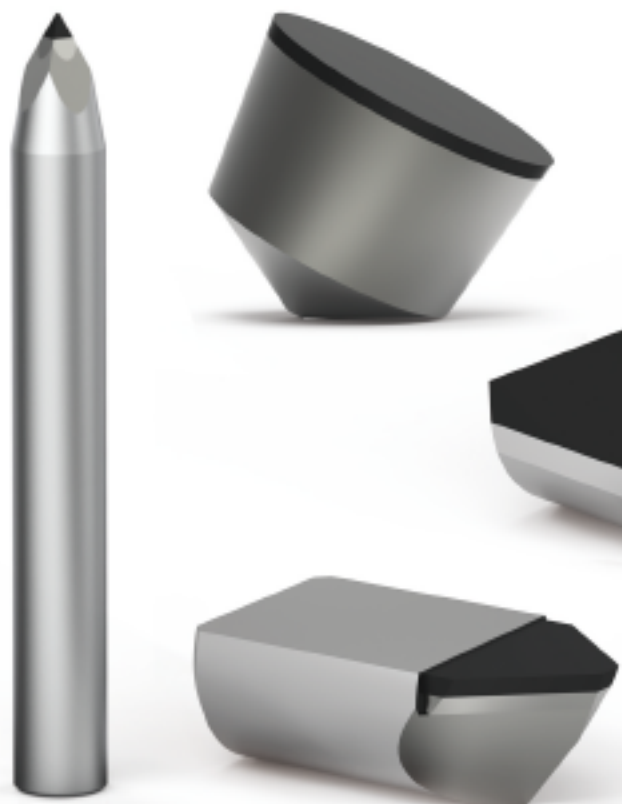

14-T15-WBV10 EN

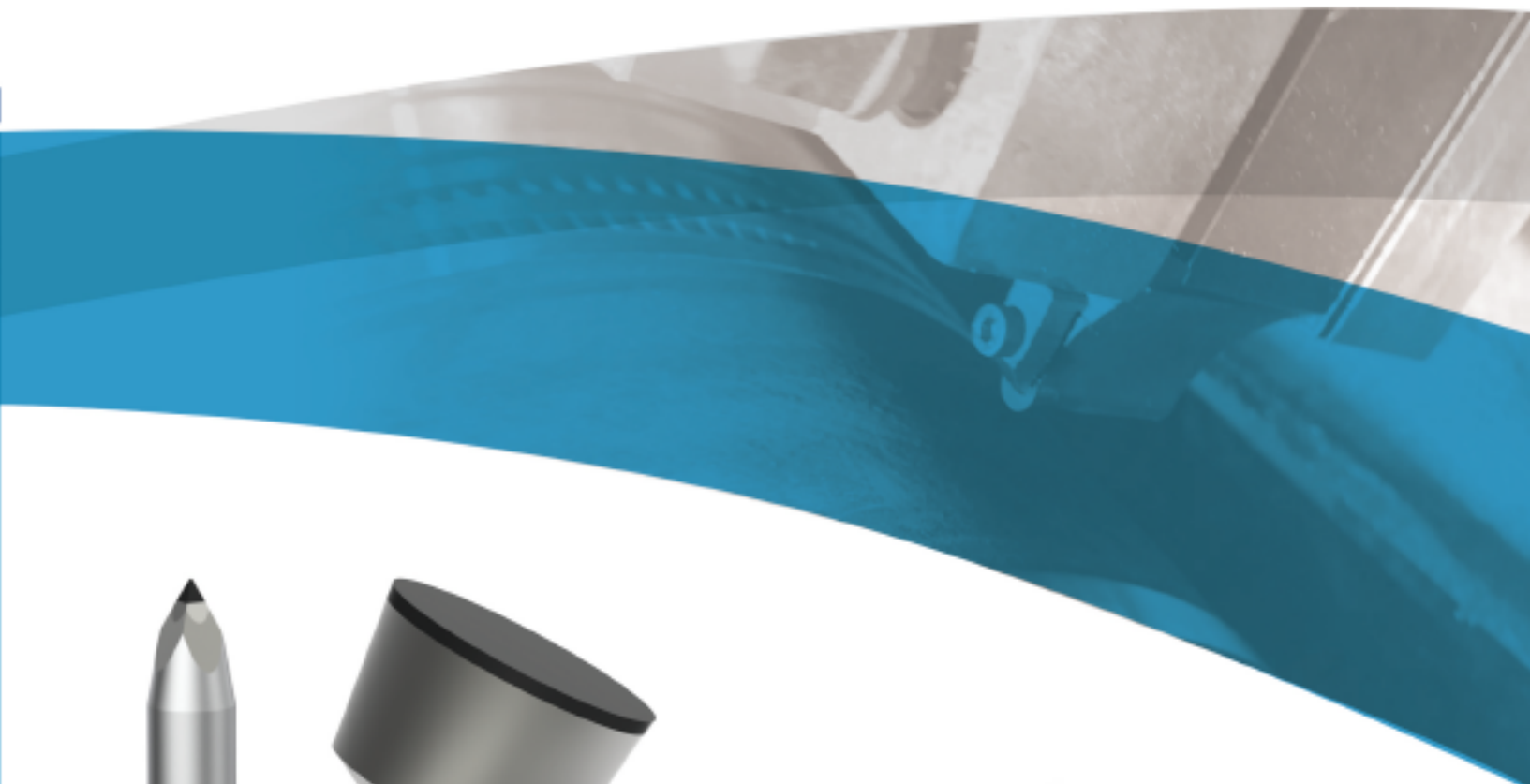

Tool solutions for steel roll industry

BEIJING WORLDIA DIAMOND TOOLS CO.,LTD.



About Us

ENTERPRISE

With the continuous development of the iron and steel industry , the quality requirements of the rolls are getting higher and higher . The rolls have high wear resistance , high hardness, and spalling resistance, which make the selection of processing tools more stringent.

Now, Beijing Worldia Diamond Tools Co., Ltd. invested in a dedicated R&D team, selected high-quality tool materials, and verified by a large number of tests. A complete set of tool supporting solutions for the steel roll industry has been developed. It is suitable for a series of processes such as rough turning of the outer circle, hole processing, crescent groove milling, engraving and marking of roll processing.

BEIJING WORLDIA DIAMOND TOOLS CO.,LTD.

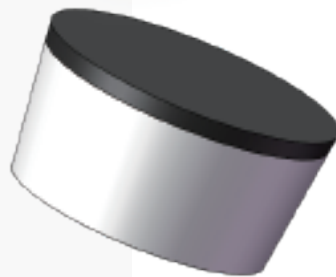
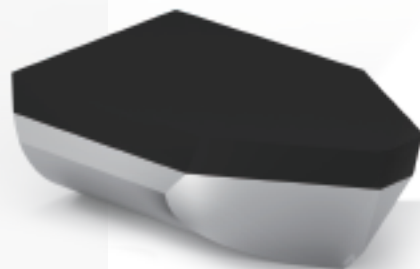
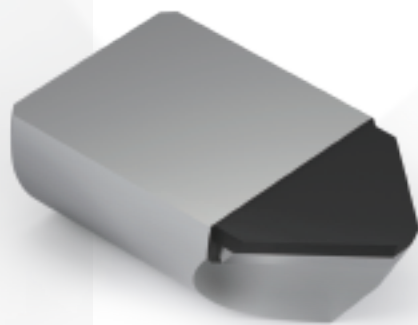

Commonly used roll materials: forged steel, cast steel, cast iron, high-speed steel, cemented carbide, etc.

According to the different requirements of roll processing materials and processing technology, Beijing Worldia Diamond Tools Co., Ltd. has developed different types of tools.

For example, PCD/PCBN round inserts used for turning the outer circle of rolls and ring grooves . A ring roller carbide milling groove alveolar boring tool, PCBN small boring tool, PCD small boring tool (small boring tool can be called rotary cutter, knife ribs, small knife,etc). And the four-sided carving knife used for engraving marks in the ring groove of the roll. It constitutes a complete set of tool solutions from roll blank to finished product processing.



INDEX

- ◆ PCD round blade 04
- ◆ PCBN round blade..... 07
- ◆ PCD small boring tool..... 08
- ◆ PCBN small boring tool 11
- ◆ Carbide small boring tool 13
- ◆ Four-sided lettering knife 14



PCD round blade

For carbide rolls and other composite rolls with a hardness above HRA85, PCD round blades can be used to process external and annular grooves. It can greatly improve the processing efficiency by using turning instead of grinding.



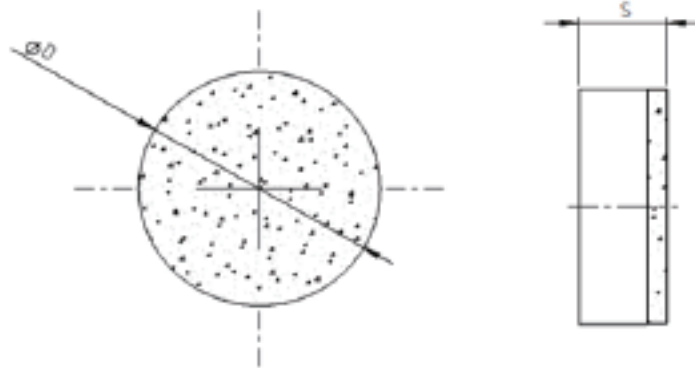

PCD round blade product advantage:

1. Using high-quality PCD raw materials, processing performance is stable.
2. Large cutting volume, strong impact resistance, good wear resistance and long life.
3. Using self-developed special machine tools for processing, the product has high precision, stable performance and high processing efficiency.

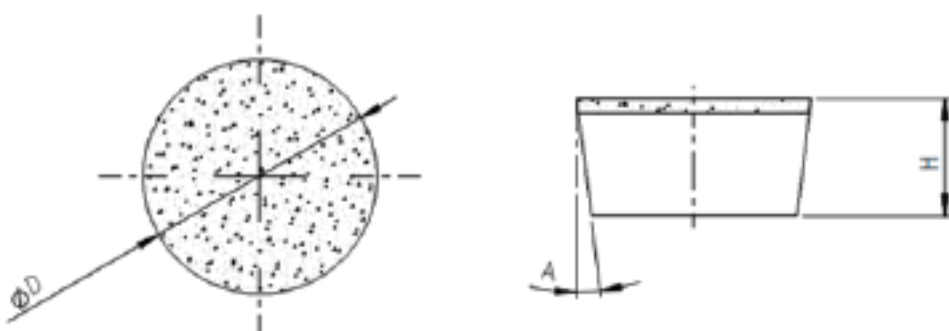

Blade shape	Specification model	Basic size	
		φD	S
	RNGN060300	6.35	3.18
	RNGN090300	9.525	3.18
	RNGN120400	12.7	4.76
	RNGN120700	12.7	7.94
	The above size can be customized according to customer needs		



Blade shape	Specification model	Basic size		
		D	H	A
	RCMN09X300	9.525	3.5	7°
	RCMN120600	12.7	6.35	7°
	The above size can be customized according to customer needs			

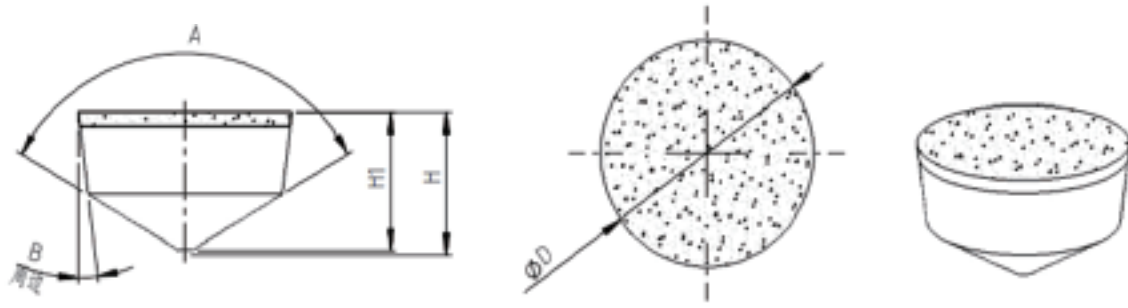

Blade shape	Specification model	Basic size				
		D	H	H1	A	B
	RCMX060500	6.5	5.0	4.8	120°	7°
	RCMX090700	9.525	7.94	7.7	120°	7°
	RCMX120700	12.7	7.94	7.7	120°	7°
	The above size can be customized according to customer needs					

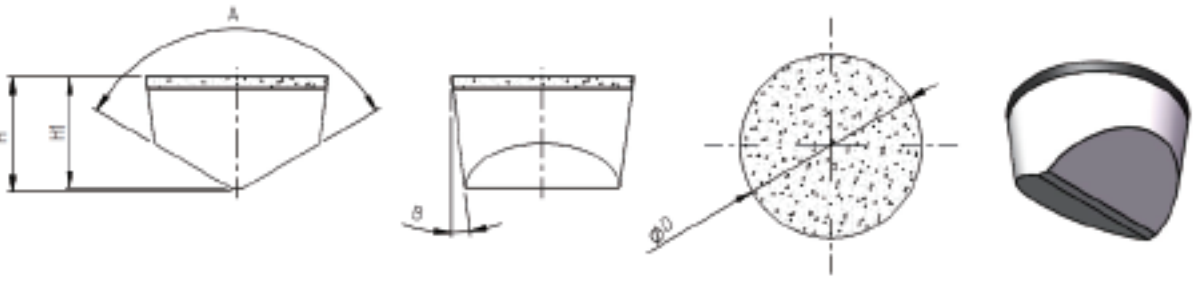

Blade shape	Specification model	Basic size				
		D	H	H1	A	
	RCMX060500-V	6.5	5.0	4.8	120°	7°
	RCMX090700-V	9.525	7.94	7.7	120°	7°
	RCMX120700-V	12.7	7.94	7.7	120°	7°
The above size can be customized according to customer needs						

PCBN round blade

The PCBN wafers produced by Beijing Worldia Diamond Tools Co., Ltd. are made of high-quality PCBN raw materials and processed by precision grinding. According to different working conditions, different cutting edge parameters are designed to better meet customer processing needs.

Generally used for ring groove turning and outer annular groove turning of forged steel, cast iron, and a hardness less than HRA85 carbonization tungsten.





According to the different positioning methods of the arbor, PCBN round blades are mainly divided into three structural forms.

- 1. RN round blade
- 2. RC round blade - cone
- 3. RC type round blade- V cone

Product advantages and applications:

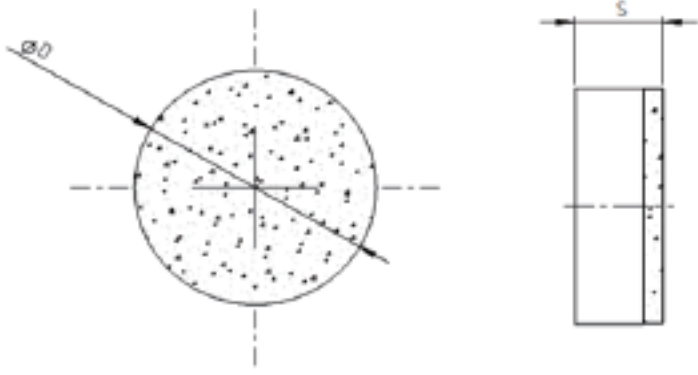
- (1) Select high-quality PCBN materials with stable quality,
- (2) Large cutting volume, strong impact resistance, good wear resistance and long life.
- (3) Using self-developed special machine tools for processing, the product has high precision, stable performance and high processing efficiency



Blade shape	Specification model	Basic size	
		ϕD	S
	RNGN060300	6.35	3.18
	RNGN090300	9.525	3.18
	RNGN120400	12.7	4.76
	RNGN120700	12.7	7.94
The above size can be customized according to customer needs			

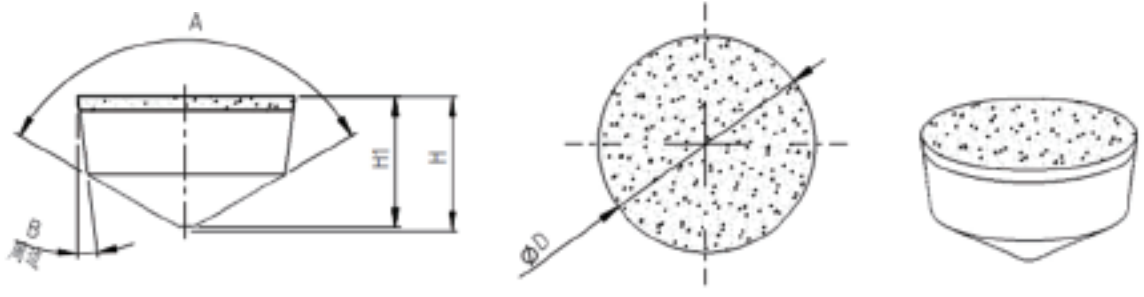

Blade shape	Specification model	Basic size				
		D	H	H1	A	B
	RCMX060500	6.35	5.0	4.8	120°	7°
	RCMX090700	9.525	7.94	7.7	120°	7°
	RCMX120700	12.7	7.94	7.7	120°	7°
The above size can be customized according to customer needs						

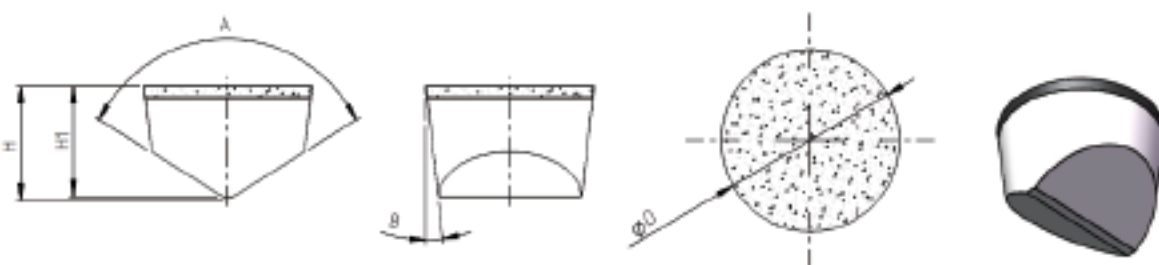

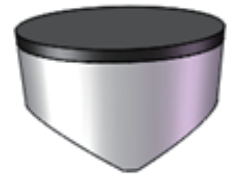
Blade shape	Specification model	Basic size				
		D	H	H1	A	B
	RCMX060500-V	6.35	5.0	4.8	120°	7°
	RCMX090700-V	9.525	7.94	7.7	120°	7°
	RCMX120700-V	12.7	7.94	7.7	120°	7°
The above size can be customized according to customer needs						

PCDsmall boring cutter

At present, the processing of rebar rolls and the crescent grooves of the roll ring mostly adopts CNC rotary flying engraving and milling machines, which are processed by rotary milling technology. Such processing methods and tools used for the smaller boring tool (alveolar rotary cutter).

According to different processing materials, Beijing Worldia Diamond Tools Co., Ltd. has developed three types of small boring cutters with different materials, namely: PCD small boring cutter, PCBN small boring cutter, and carbide small boring cutter.

Beijing Worldia PCD small boring tool has launched two different series of products, SD series and SDM series, for different customers and working conditions. In terms of structure, it is divided into two types: integral type and welded type. Generally, when the tool diameter is less than 4.0, it is recommended to use an integral small boring tool. For tool diameters above 4.0, a welded small boring tool is recommended.



Product advantages and applications:

- (1) Imported high-quality PCD materials are used, with stable quality and long service life;
 - (2) Special research and development by a professional R&D team, and the results of PCD small boring tools have national patent certificates;
 - (3) The form is simple and practical, the processing is convenient, and the performance is stable.
- It is suitable for milling the inner crescent groove of the ring groove of the high hardness carbide roll .

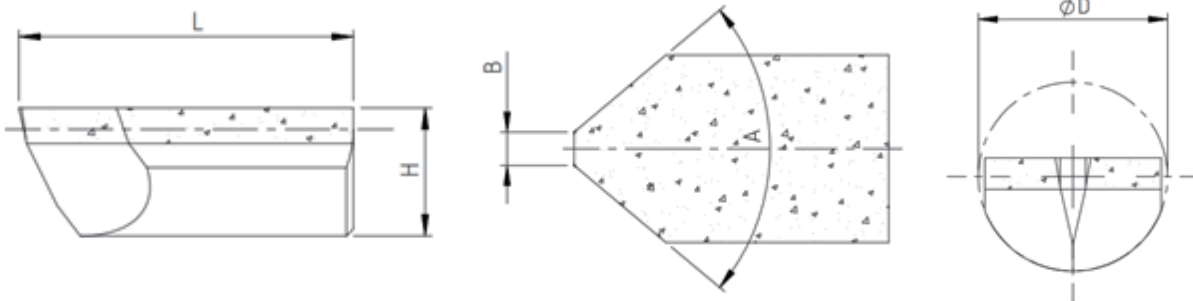
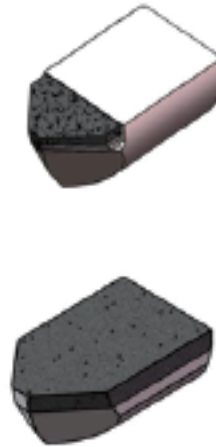

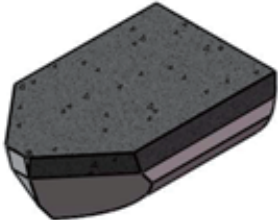
Blade shape	Specification model	Basic size					
		D(mm)	H(mm)	A (°)	B(mm)	L(mm)	
	XXAA	2.0	1.3	80	0.4	4.0	现货
		3.0	1.8	90	0.5	4.9	现货
		3.0	1.8	90	0.5	5.0	现货
		3.0	1.8	90	0.5	6.1	现货
		3.0	1.8	80	0.6	6.1	现货
		4.0	2.4	80	0.6	7.8	现货
The above size can be customized according to customer needs							

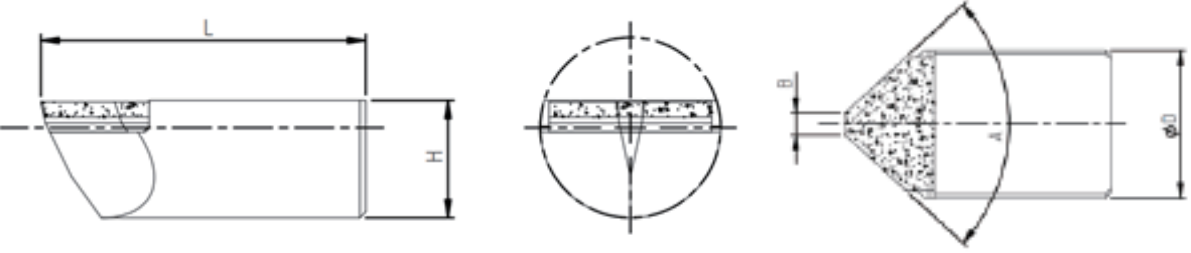

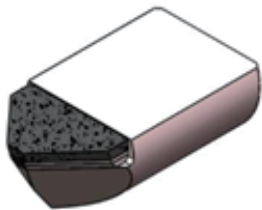
Blade shape	Specification model	Basic size				
		D(mm)	H(mm)	A (°)	B(mm)	L(mm)
	XXBA	5.0	3.2	80	0.8	9
		6.0	3.9	80	0.9	10.5
		6.0	3.9	80	1.0	11.5
		6.0	3.9	80	1.2	12.8
The above size can be customized according to customer needs						

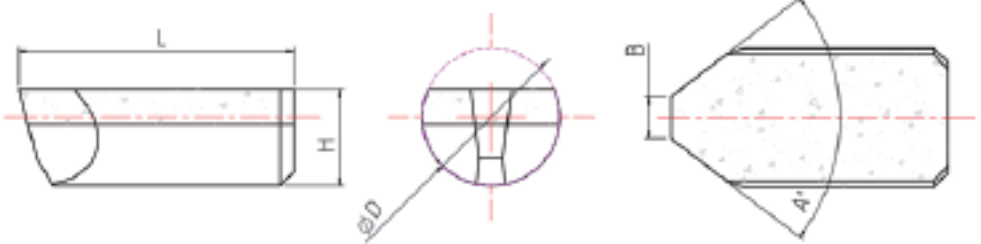

Blade shape	Specification model	Basic size				
		D(mm)	H(mm)	A (°)	B(mm)	L(mm)
	XXAA (全圆弧)	2.0	1.4	75	0.6	4.0
		2.5	1.8	80	0.7	5.3
		3.0	1.5	80	1.1	7.55
		3.2	1.6	90	1.2	8.13
		4.0	2.0	80	1.5	10.95
		4.5	2.25	90	1.6	11
		5.0	2.5	80	1.5	11.5
		6.0	3.0	80	1.7	14.1
The above size can be customized according to customer needs						

PCBN small boring tool

PCBN small boring cutters are mainly used for milling the crescent grooves of cast iron rolls and steel rolls. According to the size of the small boring tool, it can be divided into two types: integral type and welded type.

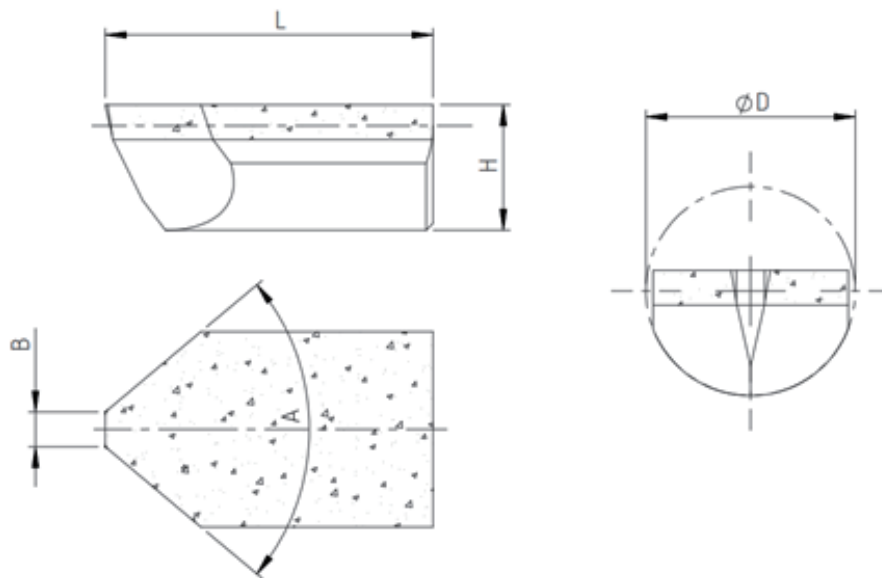

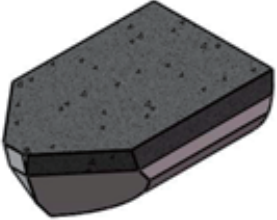
Blade shape	Specification model	Basic size				
		D(mm)	H(mm)	A (°)	B(mm)	L(mm)
	XXAA	2.0	1.4	80	0.4	4.5
		3.0	1.8	80	0.5	5.5
		3.0	1.8	80	1.6	6.5
		4.0	2.6	80	0.7	7.8
The above size can be customized according to customer needs						

Blade shape	Specification model	Basic size				
		D(mm)	H(mm)	A (°)	B(mm)	L(mm)
	XXBA	5.0	3.2	80	0.8	9
		6.0	3.9	80	0.9	10.5
		6.0	3.9	80	1.0	11.5
		6.0	3.9	80	1.2	12.8
The above size can be customized according to customer needs						

Blade shape	Specification model	Basic size				
		D(mm)	H(mm)	A (°)	B(mm)	L(mm)
	XXAA (Full arc)	2.0	1.4	75	0.6	4.0
		2.5	1.8	80	0.7	5.3
		3.0	1.5	80	1.1	7.55
		3.2	1.6	90	1.2	8.13
		4.0	2.0	80	1.5	10.95
		4.5	2.25	90	1.6	11
		5.0	2.5	80	1.5	11.5
		6.0	3.0	80	1.7	14.1
The above size can be customized according to customer needs						

Carbide small boring tool

For cast iron rolls and steel rolls, some rolls have uneven internal materials and hard spots. A small carbide boring tool can be used to process the crescent socket. On the one hand, the small carbide boring tool is cheap in unit price, and on the other hand, it has better impact resistance and is not easy to collapse.

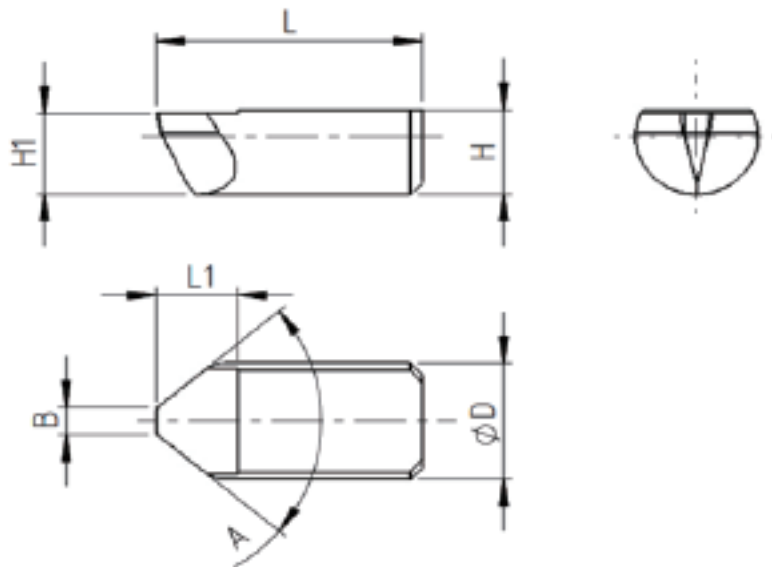
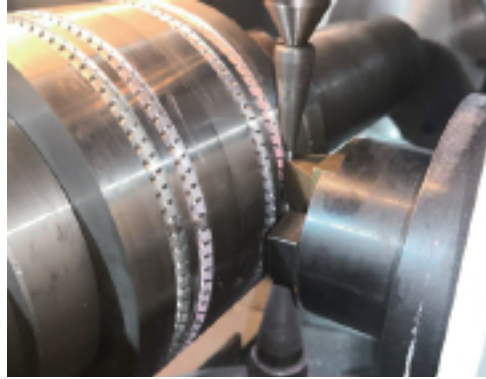

Blade shape	Specification model	Basic size				
		D(mm)	H(mm)	A (°)	B(mm)	L(mm)
	XXAA (Full arc)	2.0	1.4	75	0.6	4.0
		2.5	1.8	80	0.7	5.3
		3.0	1.5	80	1.1	7.55
		3.2	1.6	90	1.2	8.13
		4.0	2.0	80	1.5	10.95
		4.5	2.25	90	1.6	11
		5.0	2.5	80	1.5	11.5
The above size can be customized according to customer needs						

Four-sided lettering knife

Due to the extremely high hardness of the carbide material, it is particularly difficult to engrave on the surface of carbide. For this reason, Beijing Worldia invested a diamond tool--carbide-four-sided engraving knife, and has a national patent certificate.

The diamond four-sided lettering knife can engrave ultra-small and non-standard fonts and patterns on hard alloy and other hard products at high speed. Compared with other tools, it can achieve faster engraving and longer life. The surface of engraving fonts and pattern is better, and it can also engrave relatively smaller fonts and pattern.



Product advantages and applications:

- (1) Using high-quality PCD materials, stable quality and long service life
- (2) Professional R&D team, adopting multi-blade design, high processing efficiency;
- (3) Using high strength carbide, tungsten carbide bar to enhance the overall strength.
- (4) It is suitable for engraving on high hardness carbide rolls and the inner grooves of the roll ring .

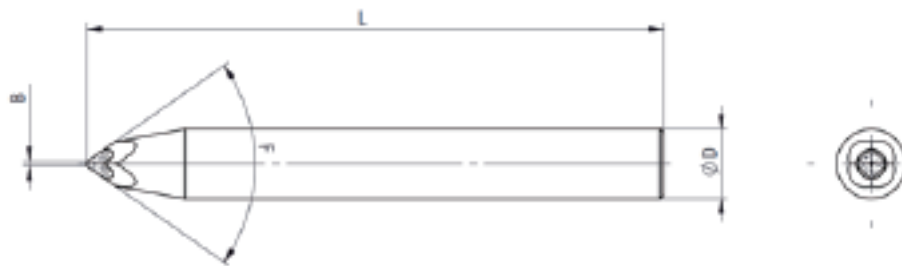

Blade shape	Specification model	Basic size			
		F (°)	B(mm)	D(mm)	L(mm)
	DKD	70	0.4	6.0	50
		70	0.5	6.0	50
		70	0.55	8.0	50
		70	0.65	10	50
The above size can be customized according to customer needs					



WORLDIA

COMPETE FOR THE TOP CREATE GLOBAL BRAND



www.worldia-tools.com

Tel: +86-10-58411388 Fax: +86-10-58411388 ext 8131

Office Add: H-03, 5F, M7 Building, No.1 Jiuxianqiao East Road, Chaoyang District, Beijing, China

Factory Add: No.2 Industry Road, Dachang Chaobaihe Industrial Park,

Langfang City, Hebei Province 065300, China

E-mail: info@worldia-tools.com

