

EMCO

MMV SERIES

**Moving Column
Machining Center**

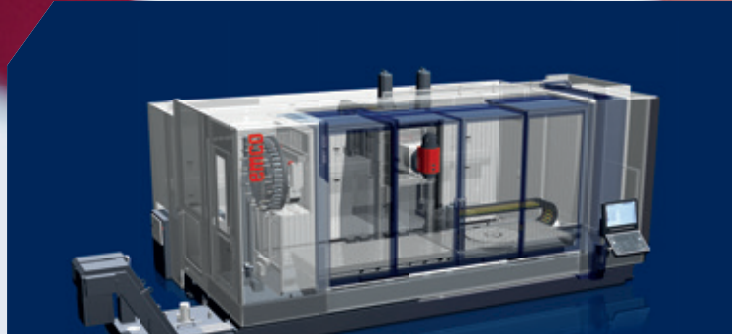

MMV SERIES 3200 4200 5200 6200

MAXIMUM PRECISION – ALSO WITH LARGE DIMENSIONS

Moving Column Machining Center for 3, 4, or 5 axes machining of big and heavy parts for small to medium lot sizes. Rapid travel up to 50 m/min with the utmost in precision. The super-structure is highly rigid, even for heavy work pieces weighing up to 8000 kg.

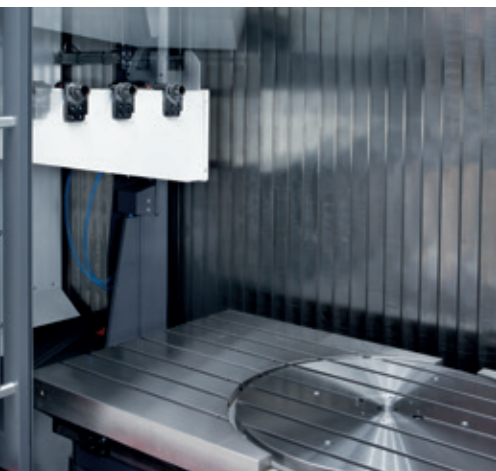

1 TOOL MAGAZINE

- / Tool changer with 40 tools and up to 120 tools depending on the machine's configuration (static or moving)
- / Thanks to the lateral magazine door (2x in case of pendulum machining), it is possible to check and set up the tools in parallel with the machining process (only in case of static magazines)

2 REAR MACHINE COMPARTMENT

- / Machine compartment partitioned by maintenance-free steel accordion way-covers

3 AXES

- / Linear roller guides in X, Y and Z directions
- / Linear scales in X, Y and Z directions
- / Direct drive in Y and Z directions
- / High dynamics

4 SPINDLE

- / Motor spindle with 15000 rpm as standard
- / Motor spindle with 18000 rpm for the HSK-A63 version
- / Motor spindle with 10000 rpm for the HSK-A100 version
- / Water-cooled

5 CONTROL

- / State-of-the-art control systems
- / SIEMENS
- / HEIDENHAIN TNC 640
- / EMCONNECT available for Sinumerik

6 CHIP CONVEYOR

- / Chip conveyor fitted as standard
- / Chip removal to the left (optional right)



Machine with optional equipment

TECHNICAL HIGHLIGHTS



High-performance motor spindle with speed range of 50-15000 rpm, power 46 kW and max. torque 170 Nm, B and C-axis with torque motors and encoders, linear scales in 3, 4 or 5 axes version as standard. The features that make the machines of the MMV series the ideal machining centres for high quality milling performance and allow the complete production of complex workpieces with excellent surface quality.

For large tools and higher cutting performance, an optional motor spindle with HSK-A100 with 10000 rpm and max. torque 270 Nm is available.

APPLICATION AREAS

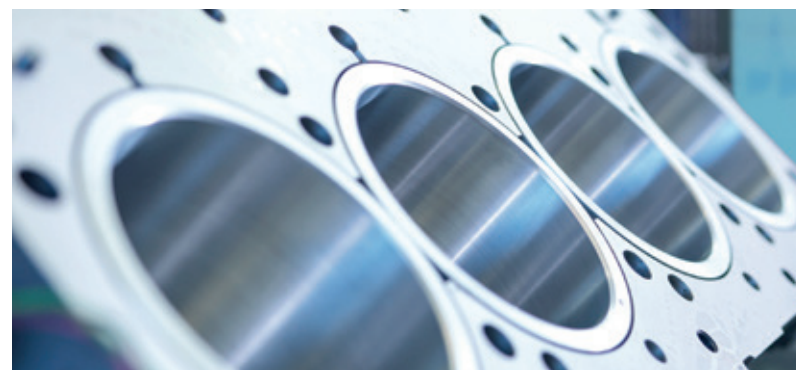

TOOL MAGAZINE

Available with steady tool magazine on 3, 4 or 5 axes version, or with moving chain magazine on 4 and 5 axes version.



CONTROL UNIT

The operator panel can travel, rotate and be adjusted in the direction of the work space. This ergonomic design provides ideal working conditions for the operator.

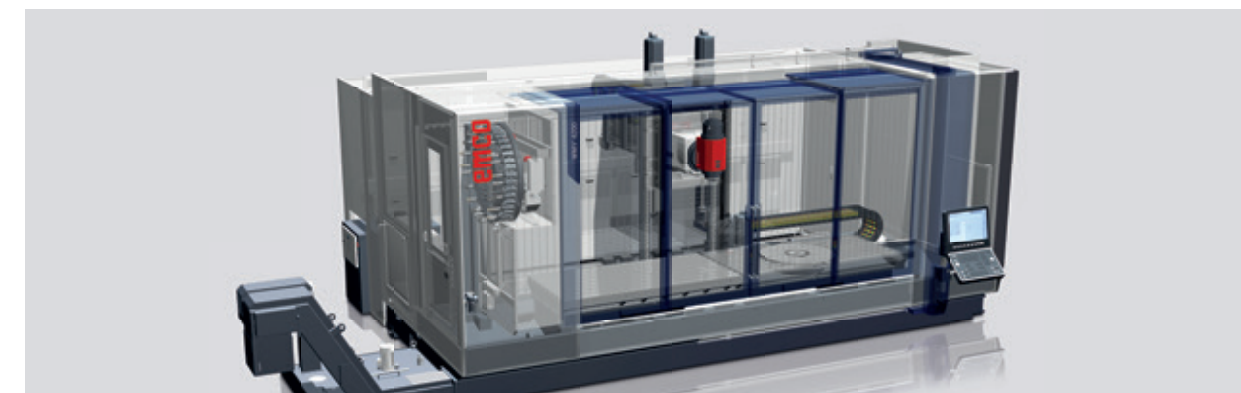

MACHINE STRUCTURE

The machine bed is a stable, structured welded steel construction. This guarantees a high degree of rigidity and excellent vibration damping, which are necessary for machining in optimal and stable conditions over time.

HIGHLIGHTS

- / Flexible modular construction and ergonomic, attractive design
- / Available as 3, 4 or 5 axes version
- / High-performance motor spindle
- / Rigid linear roller guides size 55 (X-axis)
- / Direct driven ball screws on the Y and Z-axis, precise and quiet operation
- / X-axis with rotating nut ballscrew and fixed screw (MMV 3200)
- / X-axis with rack-and-pinion drive (MMV 4200-5200-6200)
- / Integrated round table and B-axis with torque motors
- / Flexible configuration of tool magazine systems
- / State-of-the-art control systems
SIEMENS
HEIDENHAIN TNC 640
- / EMCONNECT for Siemens
- / Ideal value for money
- / Made in the Heart of Europe

TECHNICAL HIGHLIGHTS



B-AXIS

The B-axis is driven by a highly dynamic torque motor, therefore achieving a wide pivoting range of +/- 120 degrees.



Y-AXIS

The Y-axis has a ram configuration. This design uses long way guides in order to attain the required rigidity. Its high precision is guaranteed by the motor installed with a rigid coupling directly on the screw.

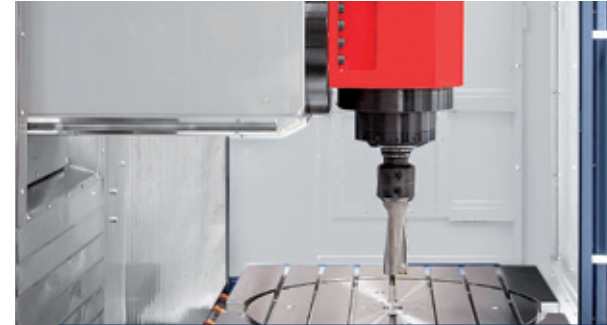

MILLING SPINDLE

The machine is equipped with a liquid cooled motor spindle with compelling performance specs. At spindle speeds of 15000 rpms, a power rating of 46 kW, and a torque of 170 Nm, the machine is also suited for heavy-duty machining. A motor spindle with 18000 rpm and identical performance data is optionally available. The HSK-A100 version consists of a motor spindle with 10000 rpm and max. 270 Nm torque.

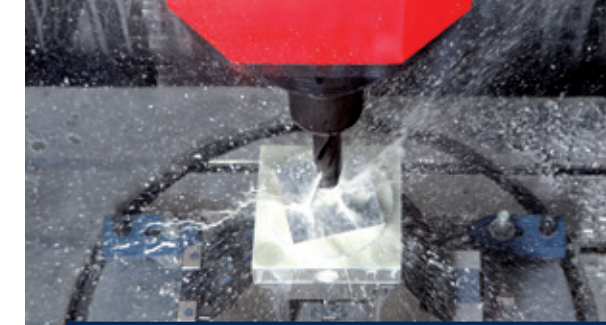

COOLANT THROUGH THE SPINDLE

The spindle can be optionally flooded with high-pressure coolant (25 to 60 bar [362,59 to 870,23 psi]). This ensures reliable chip removal from holes and pockets, reduces cycle times and increases the tool life.



HINGE TYPE CONVEYER

The chip rinsing system washes chips into the hinge type conveyor, which then automatically transports the chips from the machine into the customer provided container.

- / Workpiece and tool measurement
- / Coolant through the spindle
- / Automatic doors
- / Hydraulic device for clamping systems
- / Second integrated rotary table for 5 axes machining in pendulum operation
- / Thermal compensation of the milling spindle
- / Coolant filter systems with high-pressure pumps
- / Rotary coupling through the round table

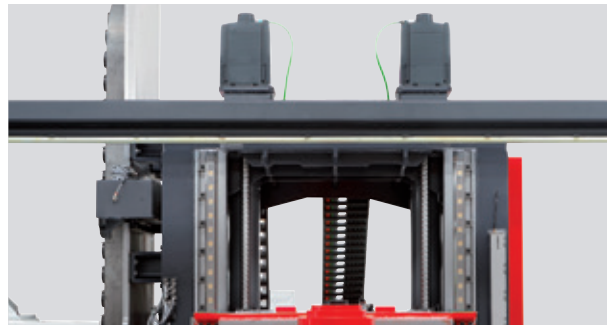

Z-AXIS TRAVEL

In order to move quickly (40m/min) and precisely with the Z-axis, due to its large mass, this axis is driven by two ballscrews and two motors in master-slave mode.



AXIS DRIVES

Equipped with rotating nut ballscrew and fixed screw. The positioning accuracy is guaranteed by the standard linear scale. Linear scales are standard on the three linear axes (X, Y and Z).



X-AXIS DRIVES MMV 4200-5200-6200

In the MMV 4200-5200-6200 machines, the X-axis is implemented with a rack and pinion drive, which guarantees maximum precision and smoothness.

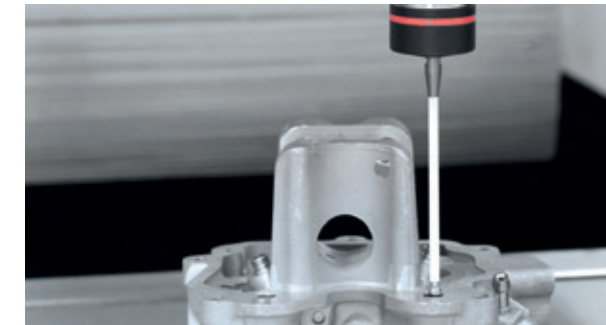

MEASUREMENT SYSTEMS

Both the measurement of the tool to reduce the set-up time during tool change as well as measuring of the workpiece to check dimensions or to determine zero points, is optionally possible within the machine by means of a radio or a laser bridge.



LARGE WORK AREA

Thanks to the large work area, it is possible to customise the machine with a wide variety of options, e.g. with a partition for pendulum operation, a rotary table, a tailstock etc.

NETWORKS ARE CREATED INDIVIDUALLY – OUR SOLUTIONS AS WELL

Staying in touch is important not only among human beings. Persons, machines and the whole production environment must also be connected perfectly and safely in order to ensure efficient procedures during the production process. With EMCONNECT, the machine is optimally equipped for this purpose. The optional EMCONNECT Digital Services offer innovative online services for optimized machine operation. The user has always the control of the machine status. The automatic notification in case of malfunctions or standstill of the machine as well as the extended capabilities for remote maintenance, minimise downtimes.

Integration into control

EMCONNECT offers several possibilities of operation according to different situations. For quick access, apps may be used simultaneously in the side panel of controlling. In this way, you can always look at your familiar numerical control, the well-known centrepiece of the machine.

An innovative concept

These powerful apps may be used independently from the control, while in the background the machine is busy in the production process. With only one click, you can change at any moment between numerical control and EMCONNECT. This is possible with the help of an innovative and ergonomic control panel, equipped with a modern 22" multi-touch display, an industrial PC with associated keyboard and HMI hotkeys.

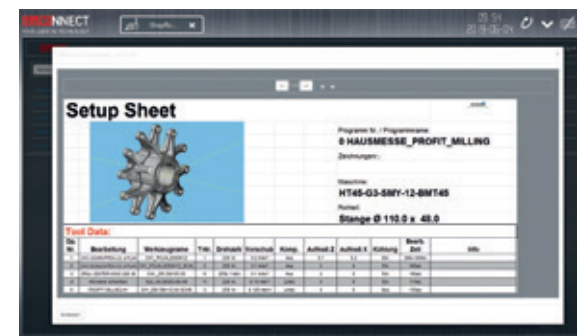

The control panel as central platform

With EMCONNECT, the control panel of the machine becomes the central platform for the access to all the operative functions. The user gets every type of support from the apps, which directly provide all the necessary applications, data and documents. In this way, EMCONNECT makes an important contribution to a highly efficient processing at the machine.



Comprehensive connectivity options

With the remote support, the web browser and the remote desktop, there are numerous connectivity options, even beyond the direct production environment. With the help of the integrated remote support, it is easily possible to carry out the remote diagnosis and remote maintenance. The optionally available OPC UA interface enables data exchange with the IT system environment and interaction with other machines for automation at shop floor level.

EMCONNECT HIGHLIGHTS AND FUNCTIONS

- / Fully connected**
Connection to all applications via remote control of the office computer and the web browser
- / Structured**
Clear monitoring of the machine state and the production data
- / Customized**
Open platform for modular integration of customer-specific applications
- / Compatible**
Interface for seamless integration into the operating environment
- / User-friendly**
Intuitive and production-optimized touch operation data
- / Future-proof**
Continuous extensions as well as easy updates and upgrades

Standard-Apps

Control	Dashboard
Machine Data	System
Remote Desktop	Web Browser
Remote Support	Settings
Cutting Calculator	Calculator
Notes	Service
Documents	EMCO TechSheet
GD&T	File Import
Shopfloor Data	Thread Reference
	Tricalc

Optional

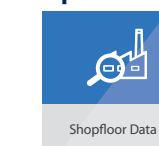

Shopfloor Data

MACHINE LAYOUT MMV 3200

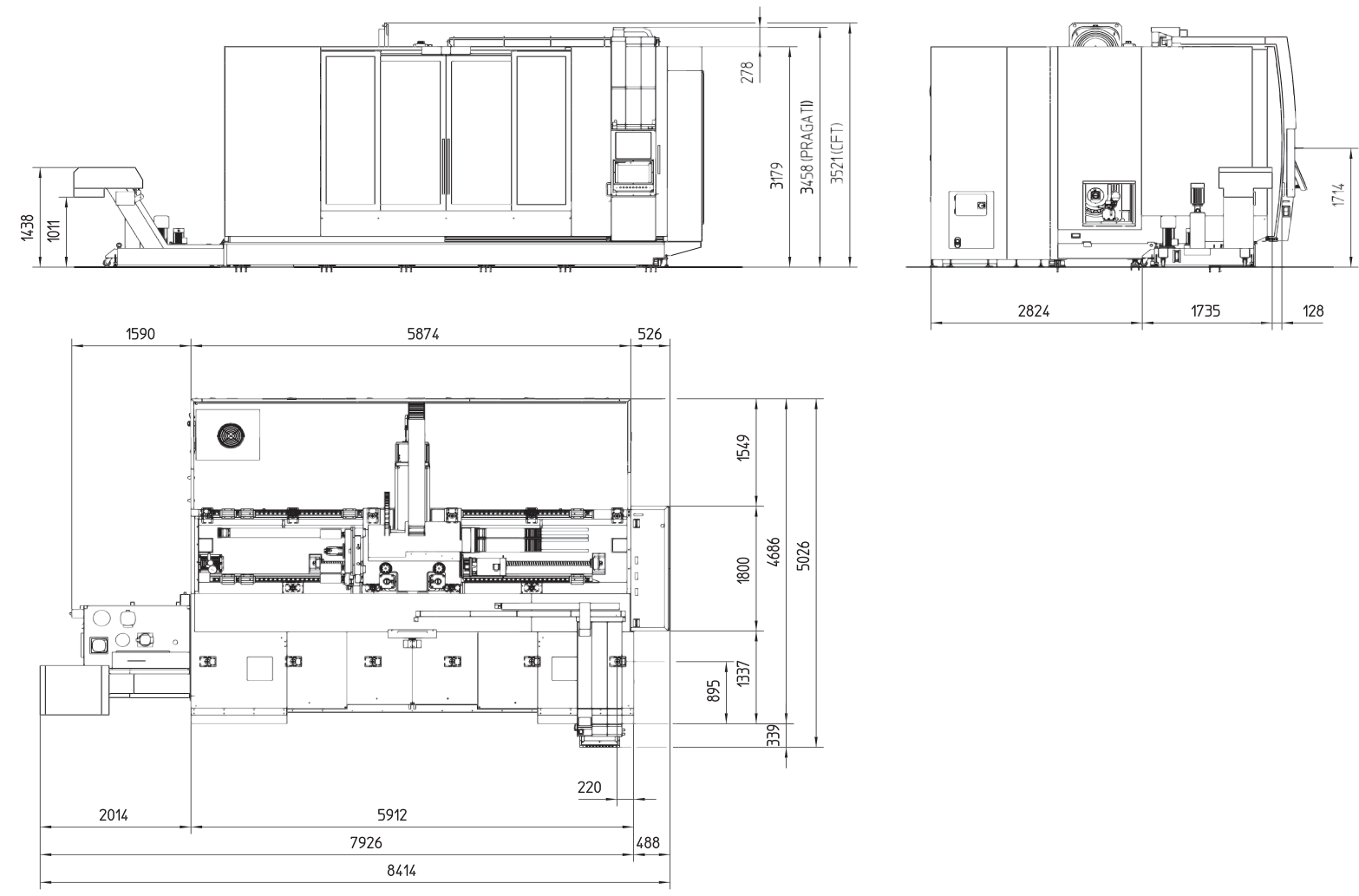

Indications in millimetres

MACHINE LAYOUT MMV 4200

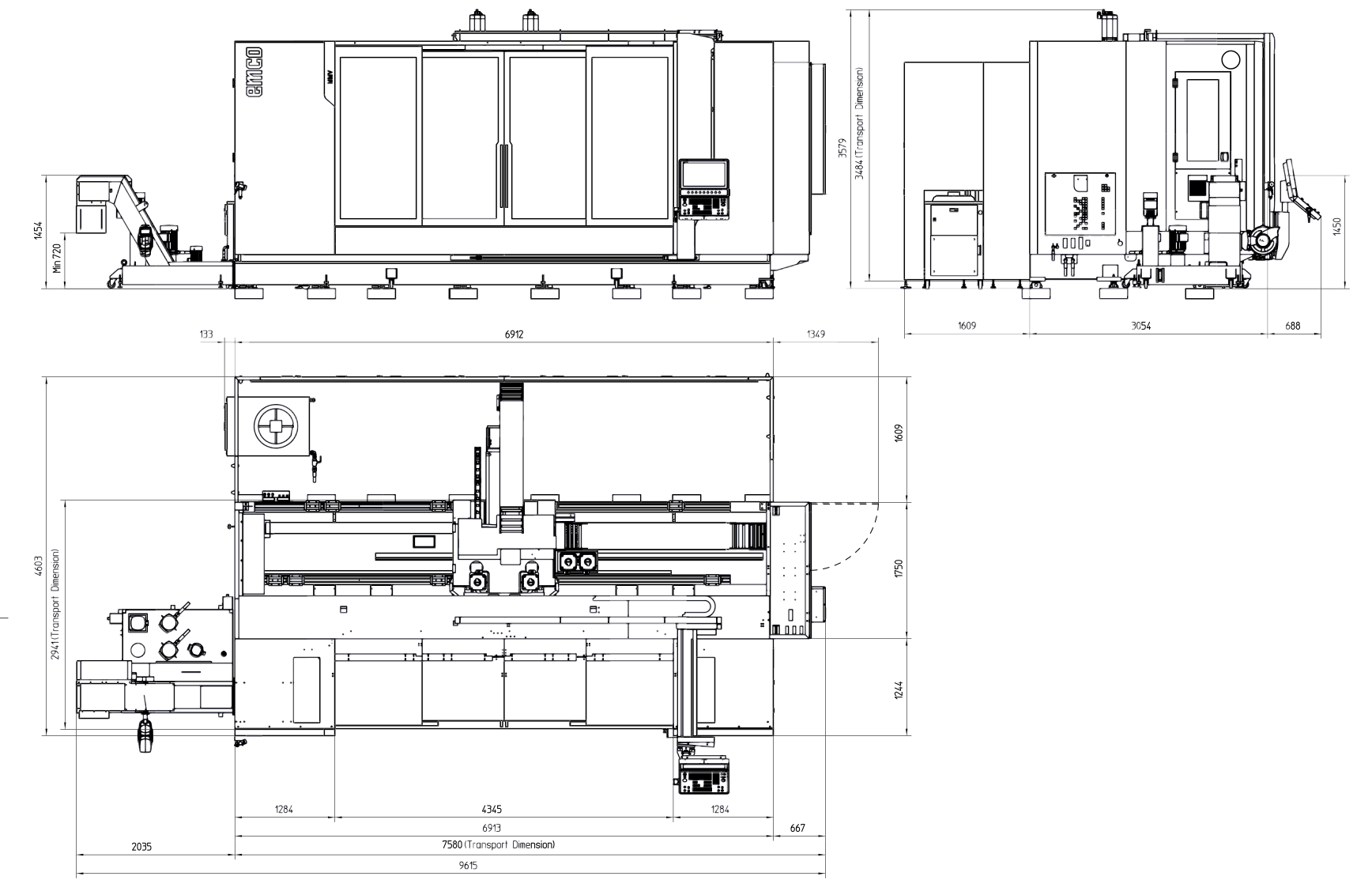

Indications in millimetres

MACHINE LAYOUT MMV 5200

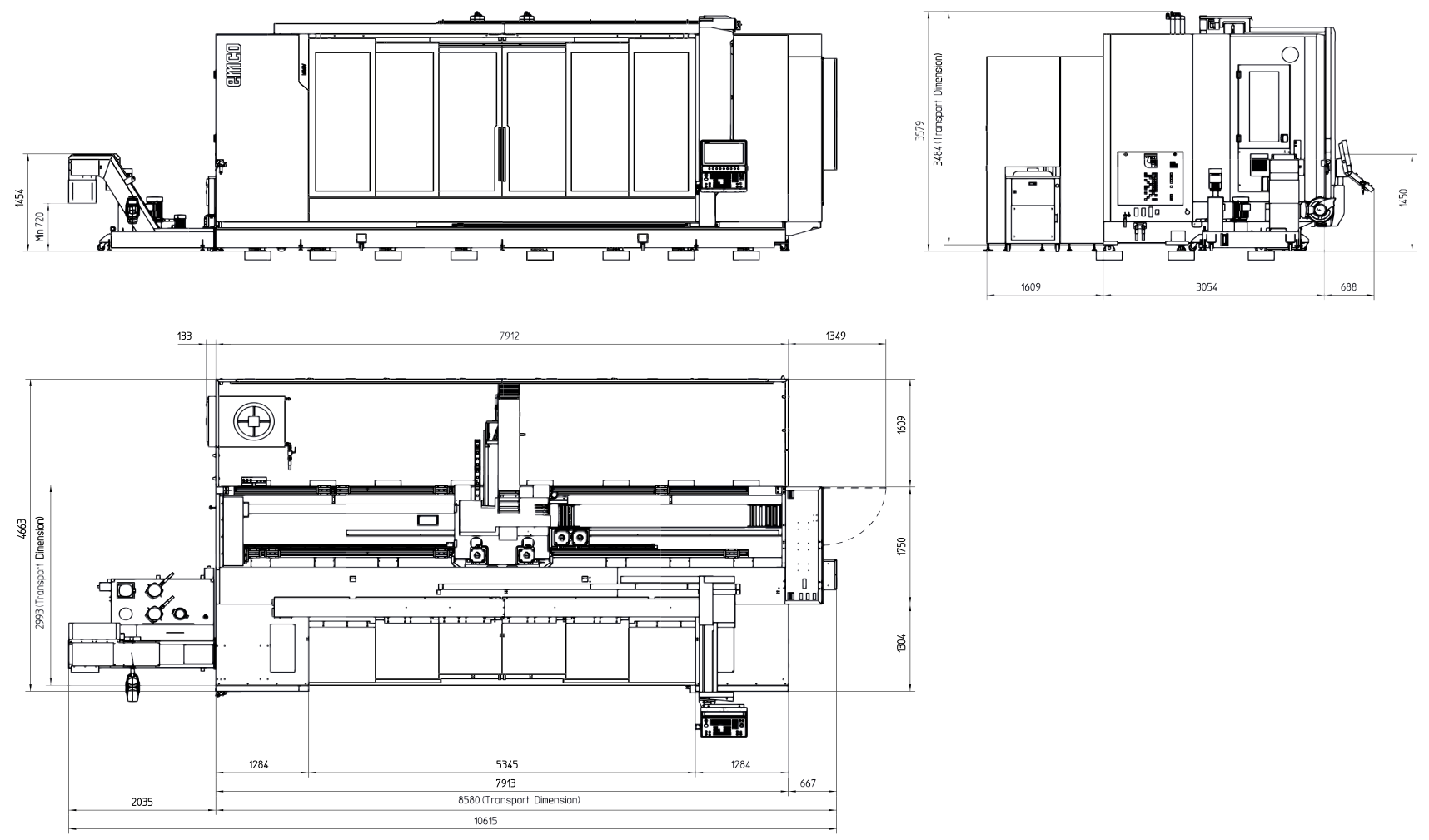

Indications in millimetres

MACHINE LAYOUT MMV 6200

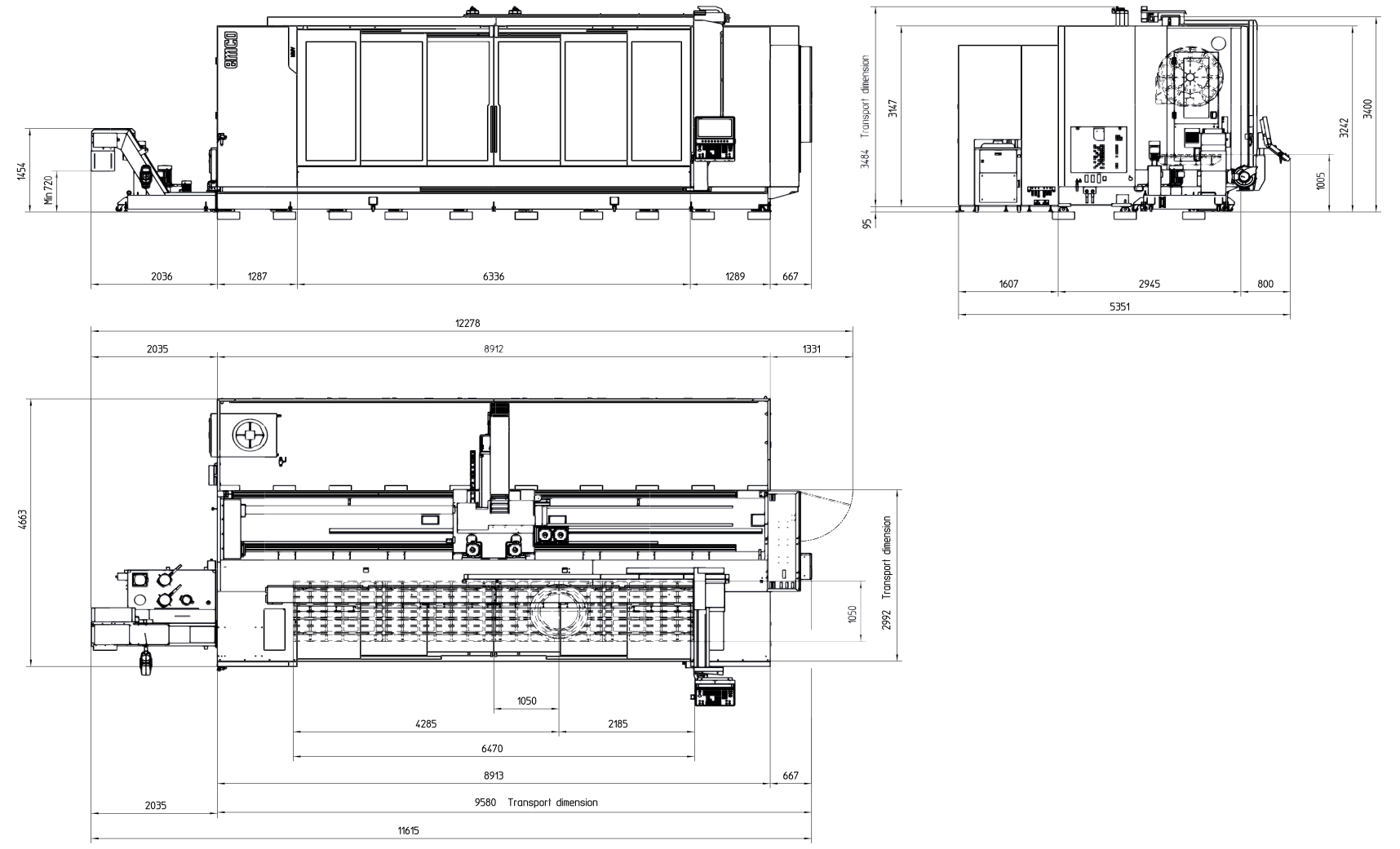

Indications in millimetres

WORKING AREA MMV 3200-6200 ISO 40 / HSK A63

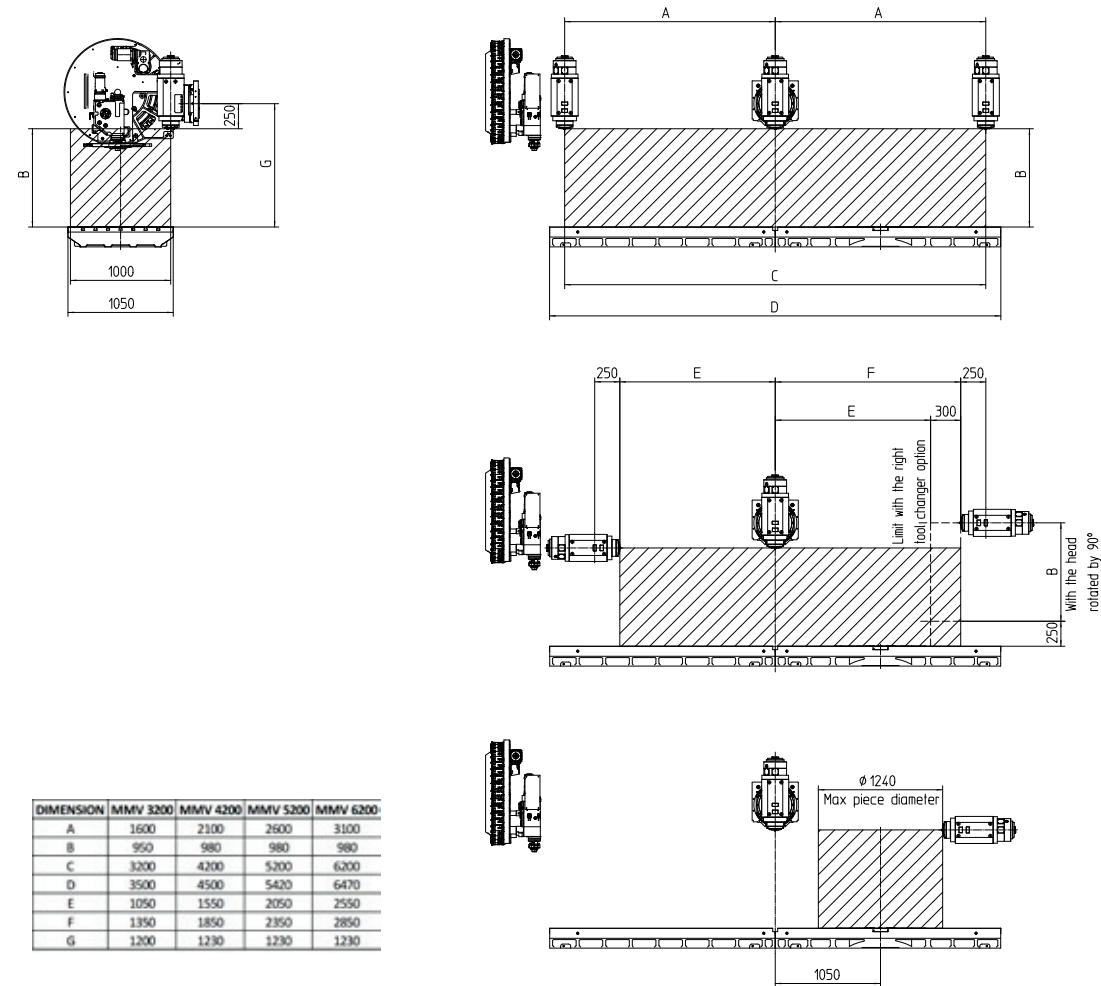

Indications in millimetres

WORKING AREA MMV 3200-6200 HSK A100

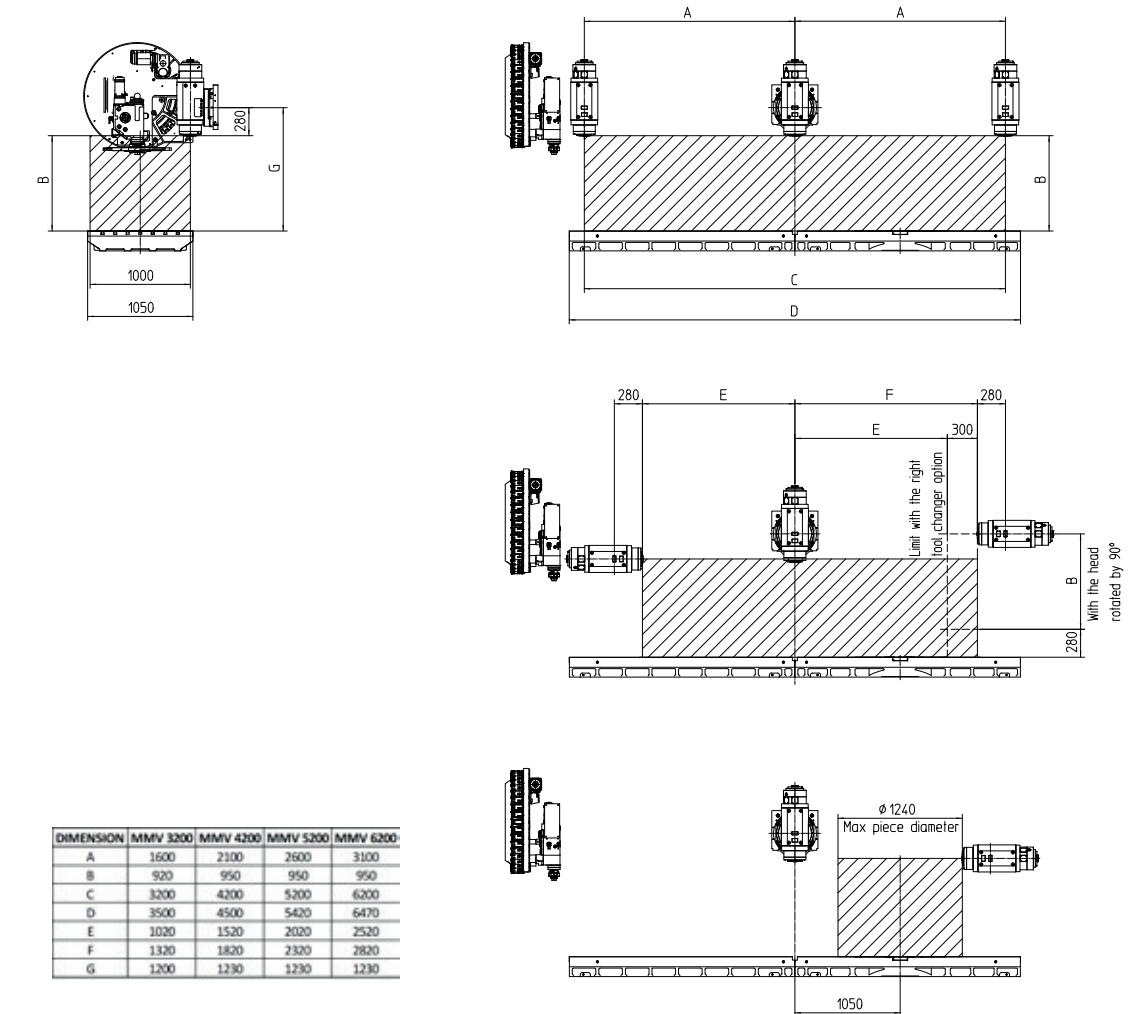

Indications in millimetres

WORKING AREA MMV 3200 ISO 40 / HSK A63
WITH PENDULUM MODE

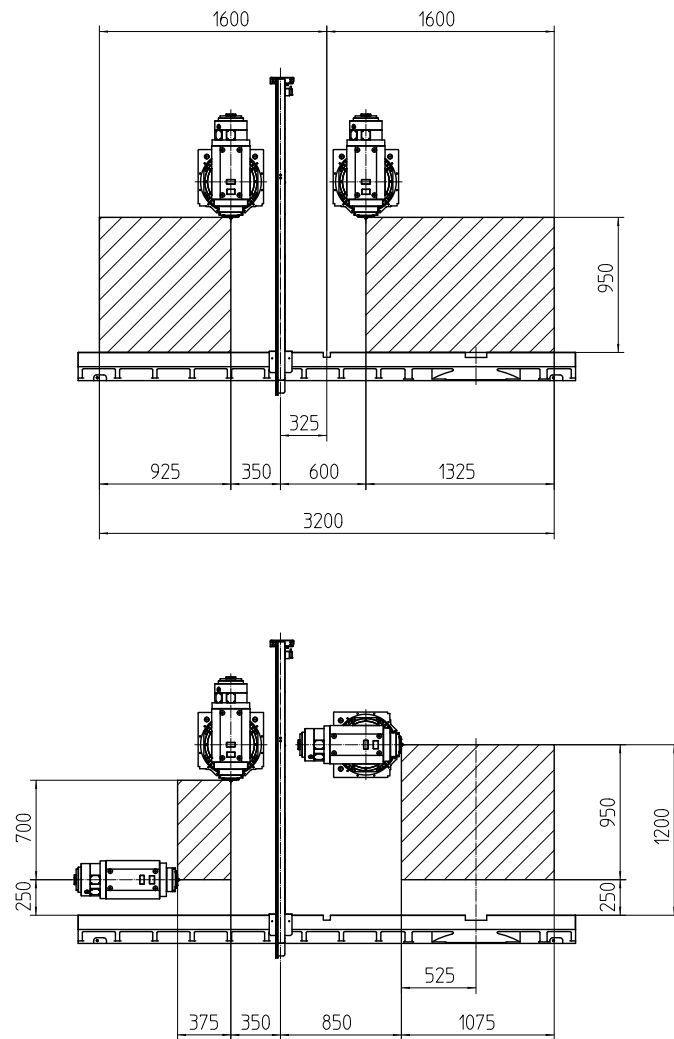

Indications in millimetres

WORKING AREA MMV 3200 HSK A100
WITH PENDULUM MODE

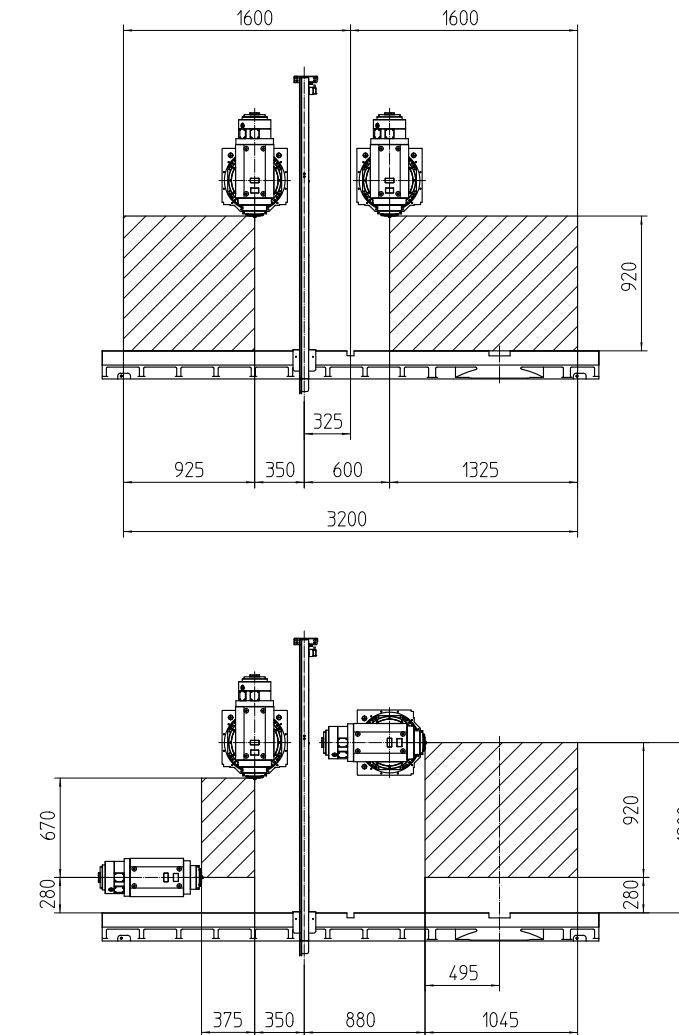

Indications in millimetres

WORKING AREA MMV 4200-6200 ISO 40 / HSK A63 WITH PENDULUM MODE

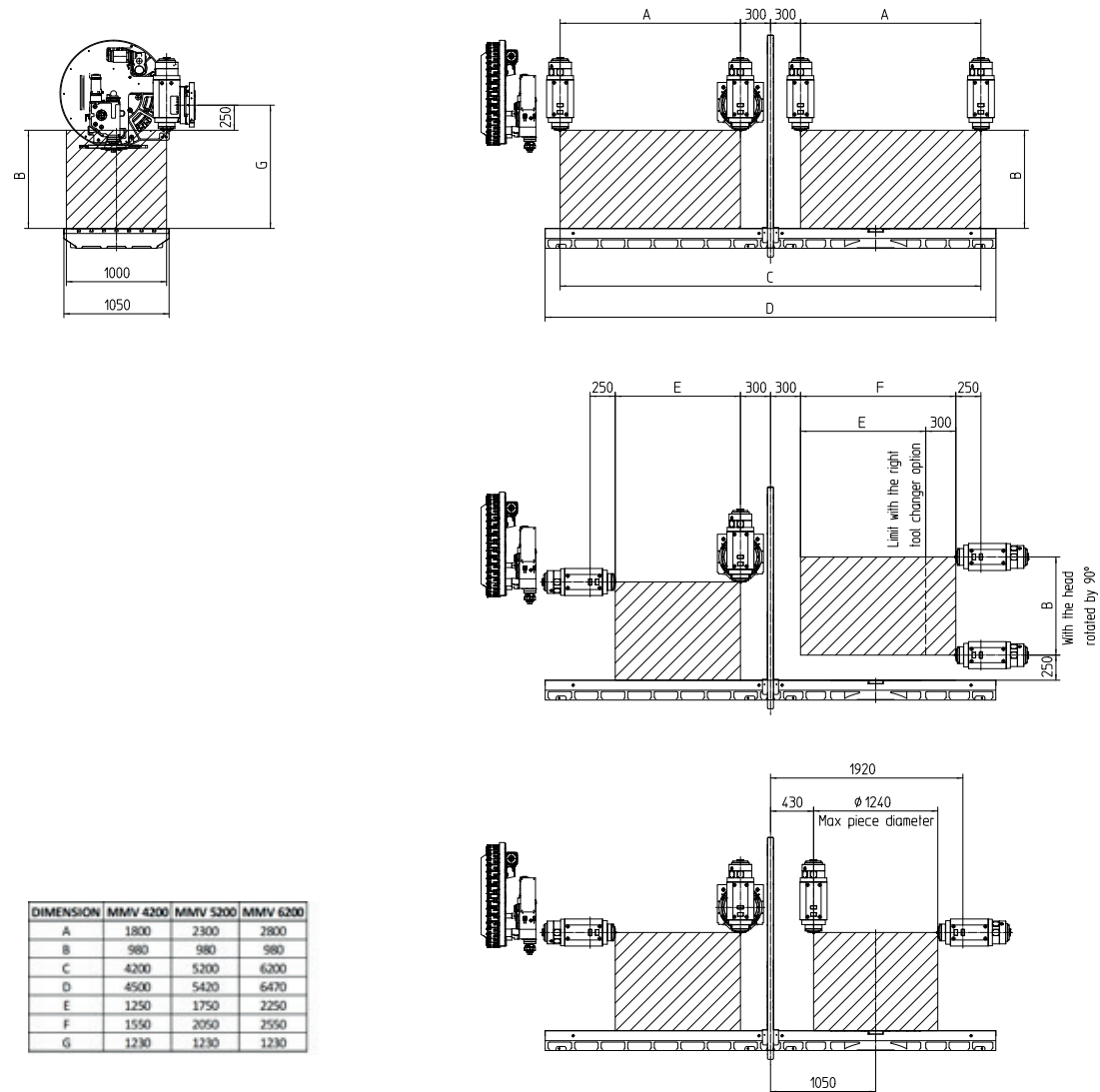

Indications in millimetres

WORKING AREA MMV 4200-6200 HSK A100 WITH PENDULUM MODE

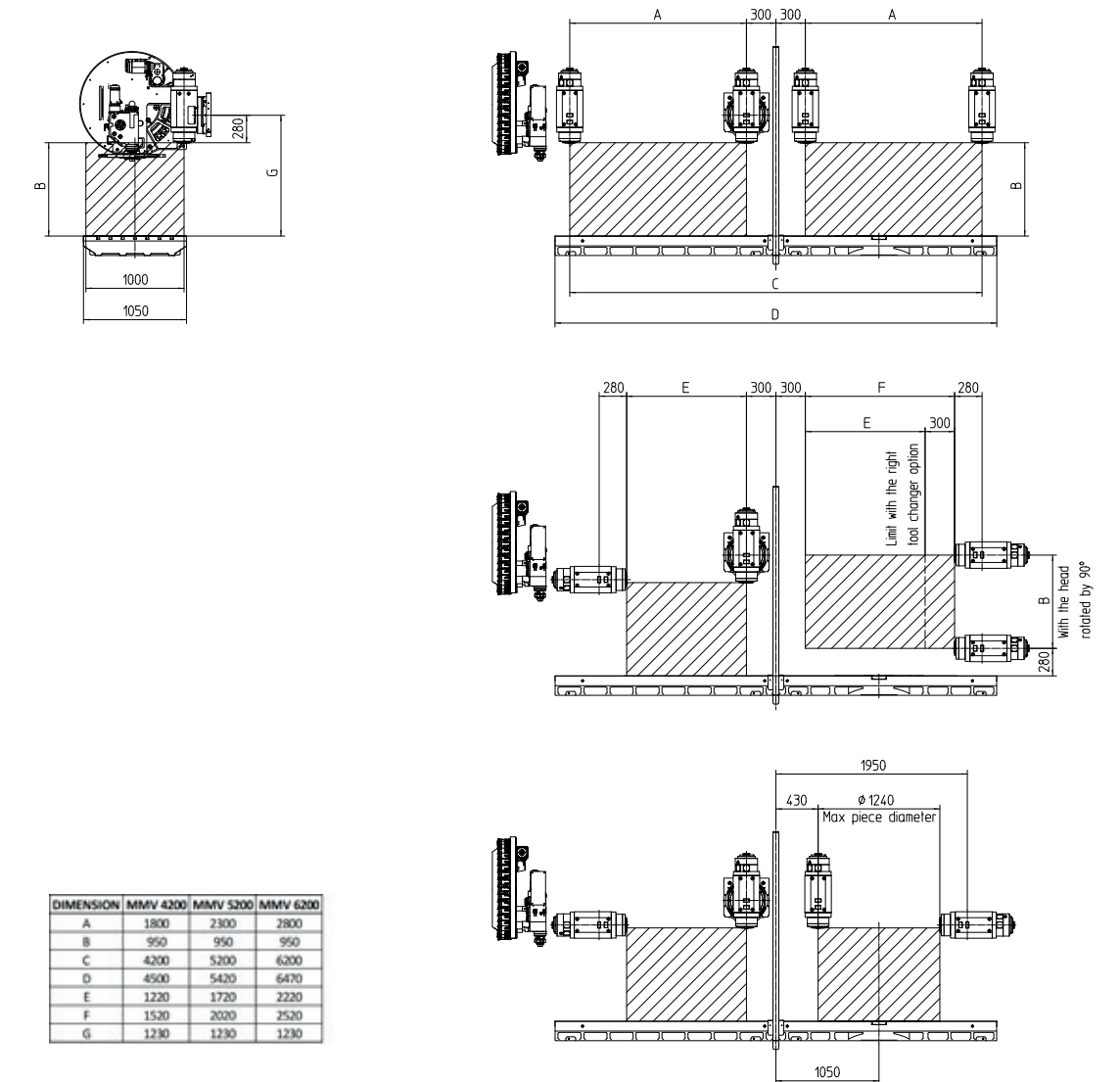

Indications in millimetres

POWER AND TORQUE

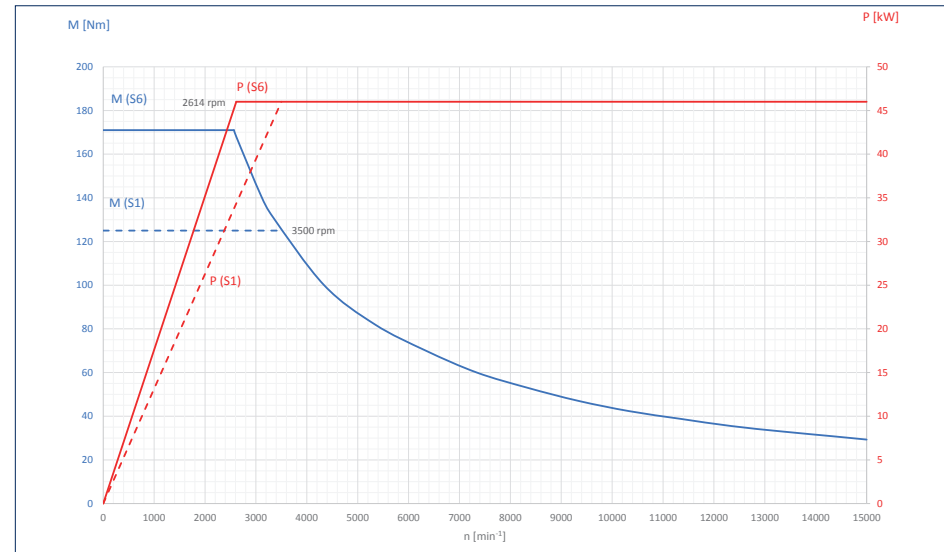

ISO 40 / HSK-A63

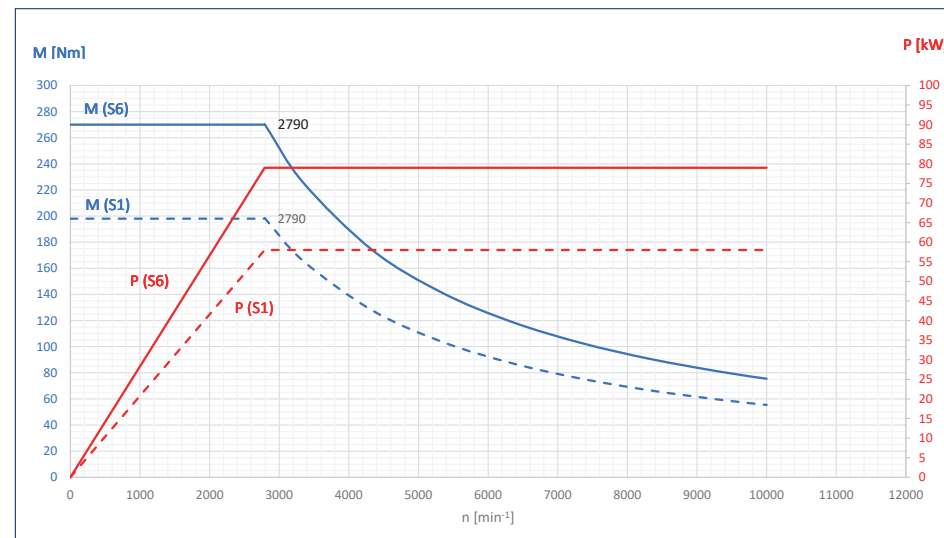

HSK-A100

TECHNICAL DATA

Travel	MMV 3200	MMV 4200	MMV 5200	MMV 6200
Travel in X-axis	3200 mm	4200 mm	5200 mm	6200 mm
Travel in Y-axis	1000 mm	1000 mm	1000 mm	1000 mm
Travel in Z-axis (ISO 40 / BT 40 / HSK-A63)	950 mm	980 mm	980 mm	980 mm
Travel in Z-axis (HSK-A100)	920 mm	950 mm	950 mm	950 mm
Min. - max. distance spindle nose - table (vertical) ISO 40 / BT 40 / HSK-A63	0 - 950 mm	0 - 980 mm	0 - 980 mm	0 - 980 mm
Min. - max. distance spindle nose - table (vertical) HSK-A100	0 - 920 mm	0 - 950 mm	0 - 950 mm	0 - 950 mm
Min. - max. distance spindle nose - table (horizontal) ISO 40 / BT 40 / HSK-A63	250 - 1200 mm	250 - 1230 mm	250 - 1230 mm	250 - 1230 mm
Min. - max. distance spindle nose - table (horizontal) HSK-A100	280 - 1200 mm	280 - 1230 mm	280 - 1230 mm	280 - 1230 mm

Feed drives

X / Y / Z rapid motion speeds	50 / 40 / 40 m/min	60 / 50 / 50 m/min	60 / 50 / 50 m/min	60 / 50 / 50 m/min
Acceleration in X / Y / Z	3 / 4 / 4 m/s ²	3 / 4 / 4 m/s ²	3 / 4 / 4 m/s ²	3 / 4 / 4 m/s ²

Table

Length	3500 mm	4500 mm	5420 mm	6470 mm
Width	1050 mm	1050 mm	1050 mm	1050 mm
Slot size	18 mm	18 mm	18 mm	18 mm
Number of slots	7	7	7	7
Slot spacing	125 mm	125 mm	125 mm	125 mm
Maximum table load (equally distributed)	5000 kg	6000 kg	7000 kg	8000 kg

Rotary table

Diameter	900 mm	900 mm	900 mm	900 mm
Maximum table load	2000 kg	2000 kg	2000 kg	2000 kg
Drive	Torque motor	Torque motor	Torque motor	Torque motor

Main spindle ISO / BT

Speed range	50 - 15000 rpm	50 - 15000 rpm	50 - 15000 rpm	50 - 15000 rpm
Torque	125 Nm (S1), 170 Nm (S6-40%)	125 Nm (S1), 170 Nm (S6-40%)	125 Nm (S1), 170 Nm (S6-40%)	125 Nm (S1), 170 Nm (S6-40%)
Spindle power	46 kW	46 kW	46 kW	46 kW
Tool taper DIN 69871 / optional	ISO 40 / BT 40	ISO 40 / BT 40	ISO 40 / BT 40	ISO 40 / BT 40

TECHNICAL DATA

Main spindle HSK-A63 HSK A63 (optional)	MMV 3200	MMV 4200	MMV 5200	MMV 6200
Speed range	50 – 18000 rpm	50 – 18000 rpm	50 – 18000 rpm	50 – 18000 rpm
Torque	125 Nm (S1), 170 Nm (S6-40%)	125 Nm (S1), 170 Nm (S6-40%)	125 Nm (S1), 170 Nm (S6-40%)	125 Nm (S1), 170 Nm (S6-40%)
Spindle power	46 kW	46 kW	46 kW	46 kW
Tool taper	HSK-A63	HSK-A63	HSK-A63	HSK-A63

Main spindle HSK-A100 (optional)	MMV 3200	MMV 4200	MMV 5200	MMV 6200
Speed range	50 – 10000 rpm	50 – 10000 rpm	50 – 10000 rpm	50 – 10000 rpm
Torque	200 Nm (S1), 270 Nm (S6-40%)	200 Nm (S1), 270 Nm (S6-40%)	200 Nm (S1), 270 Nm (S6-40%)	200 Nm (S1), 270 Nm (S6-40%)
Spindle power	79 kW	79 kW	79 kW	79 kW
Tool taper	HSK-A100	HSK-A100	HSK-A100	HSK-A100

Tool magazine (alongside column)	MMV 3200	MMV 4200	MMV 5200	MMV 6200
Number of tool stations (options)	40 (60 / 120)	40 (60 / 120)	40 (60 / 120)	40 (60 / 120)
Changeover principle	S – Arm	S – Arm	S – Arm	S – Arm
Tool management	random	random	random	random
Max. tool diameter	92 mm	92 mm	92 mm	92 mm
Max. tool diameter (without adjacent tools)	125 mm	125 mm	125 mm	125 mm
Max. tool length	300 mm	300 mm	300 mm	300 mm
Max. tool weight	8 kg	8 kg	8 kg	8 kg
Max. tool magazine weight	180 kg (240 kg / 360 kg)	180 kg (240 kg / 360 kg)	180 kg (240 kg / 360 kg)	180 kg (240 kg / 360 kg)

Tool magazine (stationary) ISO 40 / BT 40 / HSK-A63	MMV 3200	MMV 4200	MMV 5200	MMV 6200
Number of tool stations (options)	40 (60 / 80 / 100)	40 (60 / 80 / 100)	40 (60 / 80 / 100)	40 (60 / 80 / 100)
Changeover principle	S-Arm	S-Arm	S-Arm	S-Arm
Tool management	random	random	random	random
Max. tool diameter	75 mm	75 mm	75 mm	75 mm
Max. tool diameter (without adjacent tools)	125 mm	125 mm	125 mm	125 mm
Max. tool length	380 mm	380 mm	380 mm	380 mm
Max. tool weight	8 kg	8 kg	8 kg	8 kg
Max. tool magazine weight	160 kg	160 kg	160 kg	160 kg

Tool magazine (stationary) HSK-A100	MMV 3200	MMV 4200	MMV 5200	MMV 6200
Number of tool stations (options)	24 (40)	24 (40)	24 (40)	24 (40)
Changeover principle	S-Arm	S-Arm	S-Arm	S-Arm
Tool management	random	random	random	random
Max. tool diameter	125 mm	125 mm	125 mm	125 mm
Max. tool diameter (without adjacent tools)	200 mm	200 mm	200 mm	200 mm
Max. tool length	400 mm	400 mm	400 mm	400 mm
Max. tool weight	20 kg	20 kg	20 kg	20 kg
Max. tool magazine weight	200 kg (400 kg)	200 kg (400 kg)	200 kg (400 kg)	200 kg (400 kg)

Lubrication

	MMV 3200	MMV 4200	MMV 5200	MMV 6200
Guides	Automatic central lubrication with grease	Automatic central lubrication with grease	Automatic central lubrication with grease	Automatic central lubrication with grease
Ballscrews	Automatic central lubrication with grease	Automatic central lubrication with grease	Automatic central lubrication with grease	Automatic central lubrication with grease

Dimensions/weight

	MMV 3200	MMV 4200	MMV 5200	MMV 6200
Overall height	3458 mm	3580 mm	3580 mm	3580 mm
Dimensions w x d (with chip conveyor)	8414 mm x 5026 mm	9615 mm x 5350 mm	10615 mm x 5350 mm	11615 mm x 5350 mm
Total weight of machine (ISO 40 / BT 40 / HSK-A63)	24000 kg	29000 kg	33000 kg	36000 kg
Total weight of machine (HSK-A100)	25500 kg	30000 kg	34000 kg	37000 kg

beyond standard /

EMCO GmbH / Salzburger Str. 80 / 5400 Hallein-Taxach / Austria / T +43 6245 891-0 / F +43 6245 86965 / info@emco.at

www.emco-world.com